

# Dual Modular Safety Shutoff Valves

## DMV-D/11 Series DMV-DLE/11 Series

**DUNGS**<sup>®</sup>  
Combustion Controls

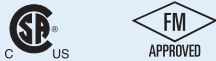

**Two normally closed safety shutoff valves in one housing; each with the following approvals.**

### CSA Certified

- ANSI Z21.21 • CSA 6.5
- Marked C/I
- File # 157406

### FM Approved

- Class 7411
- File # J.I. 3007653

### Commonwealth of Massachusetts Approved Product

- Approval code G1-1107-35
- Gas Safety Shutoff Valve

### EU Gas Appliance Directive

- EN161
- CE-0087AU30

### Codes and Standards:

This product is intended for installations covered by but not limited to NFPA 86, NFPA 37, or CSA B149.3.

**DUNGS is an ISO 9001 manufacturing facility.**

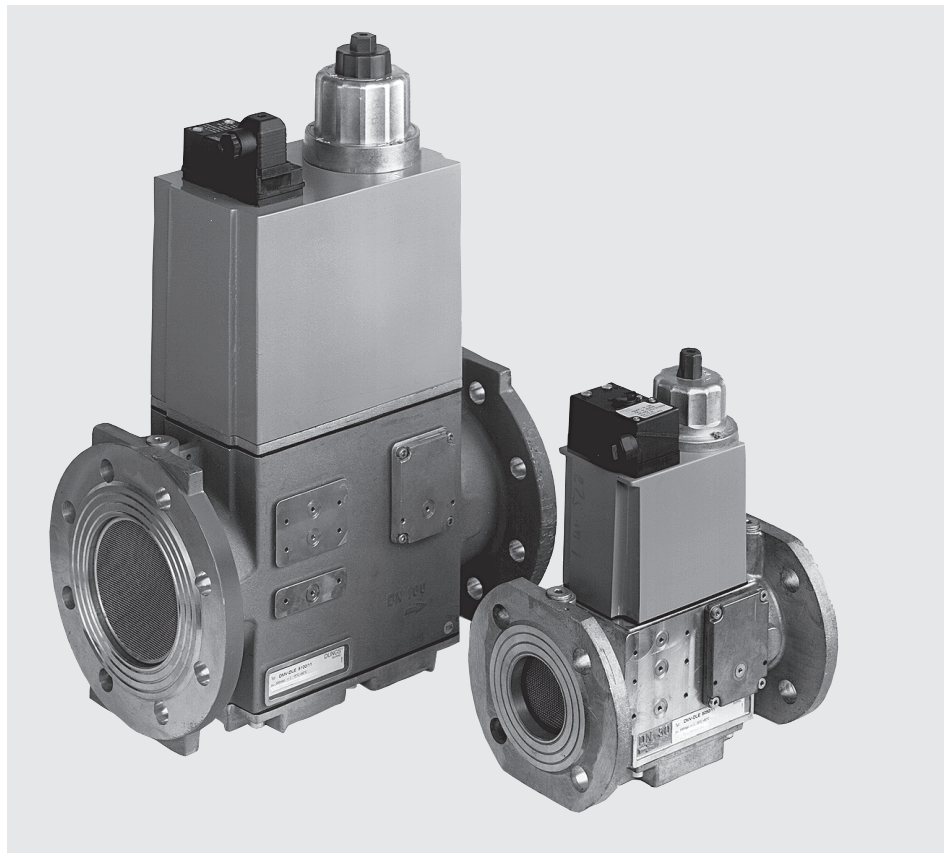

### Description

The DUNGS Dual Modular Valve (DMV) combines two safety shutoff valves in one compact housing, which can be wired independently or in parallel.

Valve 1 (V1) of the DMV-D and DMV-DLE series is fast opening and fast closing. Valve 2 (V2) of the DMV-D is fast opening, while V2 of the DMV-DLE is slow-opening for smoother light-off. Max. flow adjustment on V1 provides variable main flow on both models.

Internal profiles and compact design optimize flow and provide a low pressure drop.

Directly mounting the following DUNGS accessories creates a compact valve train without additional piping:

- High and low gas pressure switches
- Valve proving system

### Application

The DUNGS DMV is recommended for industrial and commercial heating applications that require two safety shutoff valves. The DMV Dual Modular Valve is suitable for natural gas, propane, butane, air and other inert gases. Suitable for up to 0.1% by volume, dry H<sub>2</sub>S.

**DMV-D.../11** Two normally closed safety shutoff valves in one housing. V1 and V2 are fast opening, fast closing. Adjustable max. flow with V2.

**DMV-DLE.../11** Two normally closed safety shutoff valves in one housing. V1 fast opening, fast closing. V2 is slow opening, fast closing. Adjustable max. flow and adjustable initial lift with V2.

## Specifications

Flange sizes	DN 40 ( 1 1/2") 50 (2") 65 (2 1/2") 80(3") 100(4") 125 (5") Connection flange as per DIN 2501 Part 1, to fit pre-weld flanges as per DIN 2633 (PN 16) DN 40 to DN 125, ISO 7005 - 1 (PN 16), or ISO 7005 - 2 (PN 16).		
Max. operating pressure	7 PSI (500 mbar) FM, CE (Class A)	5 PSI (360 mbar) CSA	
Max. body pressure	15 PSI (1000 mbar)		
Max. close off pressure	7 PSI (500 mbar) FM, CE (Class A)	5 PSI (360 mbar) CSA	
Electrical ratings (+10% / -15%)	110 - 120 VAC/50-60 Hz and 24 VDC. Part numbers listed on page 3. 220 - 240 VAC/50-60 Hz and 24 VAC/ 50-60 Hz models available upon request		
Power rating for	Version	Approx. rating [VA]	Approx. operating current [A]
Coil Type 1212	DMV-D(LE) 5040/11	90	0.74 A @ 120Vac/3.8 A @24Vdc
Coil Type 1212	DMV-D(LE) 5050/11	90	0.74 A @ 120Vac/3.8 A @24Vdc
Coil Type 1411	DMV-D(LE) 5065/11	110	0.92 A @ 120Vac/4.6 A @24Vdc
Coil Type 1511	DMV-D(LE) 5080/11	110	0.92 A @ 120Vac/4.6 A @24Vdc
Coil Type 1611	DMV-D(LE) 5100/11	135	1.12 A @ 120Vac/5.6 A @24Vdc
Coil Type 1711	DMV-D(LE) 5125/11	200	1.68 A @ 120Vac/8.3 A @24Vdc
Enclosure rating	NEMA Type 12		
Electrical connection	DIN-connector with 1/2" NPT conduit adapter		
Operating time	100 % duty cycle		
Closing time	< 1 s		
Opening time (to max. flow)	DMV-D.../11 V1 & V2 < 1 s DMV-DLE.../11 V1 < 1 s; V2 Adjustable to approx. 10 to 20 s at 70 °F		
Initial lift adjustment	Adjustable on V2 DLE only; 0 to 70 % of total flow; 0 to 25% of stroke		
Max. flow adjustment	Adjustable on V1 <10 to 100 % of total flow; <10 to 100% of stroke		
Materials in contact with gas	Housing: Aluminum & Steel free of non-ferrous metals Valve seats: NBR-based rubber		
Ambient temperature rating	+5°F to +140 °F (-15 °C to +60 °C)		
Installation position	Safety valve upright to lying horizontally		
Gas strainer (standard)	Installed in the housing upstream V1 (23 mesh)		
Position indication (order separately)	CPI 400 with indication lamps and SPDT interlock switch or Visual indicator (VI)		
Test ports / Pressure switch mounting ports	G 1/8 ISO 228 ports available on both sides. Each side has two ports upstream V1, one between V1 and V2, one downstream V2. G 1/4 ISO 228 on both flanges, upstream of V1, downstream of V2		
Valve proving system	VPS 504; mounts directly to either side of DMV.		

**Dimensions inch (mm)**

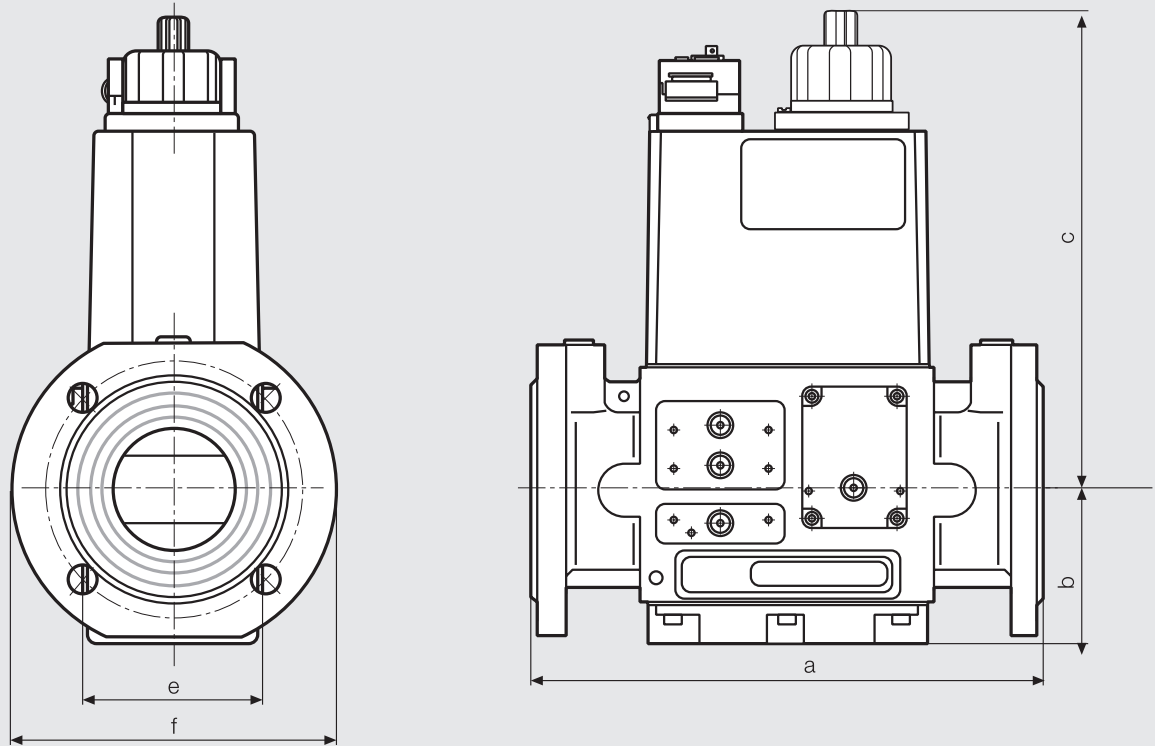

Type	110-120 VAC 50-60 Hz Order No.	24VDC Order No.	p <sub>max.</sub> [PSI]	Connection DN	Dimensions [inch]					Weight		
					Dimensions [mm]					[lbs]	[kg]	
					a	b	c	e	f			
DMV-D	5040/11	226-061	226-063	7	DN 40	<b>9.5</b>	<b>2.5</b>	<b>7.6</b>	<b>3.9</b>	<b>5.9</b>	<b>17.2</b>	
						240	62,5	192	100	150	7.8	
DMV-D	5050/11	226-064	226-066	7	DN 50	<b>9.5</b>	<b>2.9</b>	<b>7.6</b>	<b>3.9</b>	<b>6.5</b>	<b>18.3</b>	
						240	73	192	100	165	8.3	
DMV-D	5065/11	226-067	226-069	7	DN 65	<b>11.4</b>	<b>3.4</b>	<b>9.9</b>	<b>4.0</b>	<b>7.3</b>	<b>32.2</b>	
						290	87	251	102	185	14.6	
DMV-D	5080/11	226-070	226-072	7	DN 80	<b>12.2</b>	<b>4.1</b>	<b>11.5</b>	<b>5.1</b>	<b>7.9</b>	<b>52.0</b>	
						310	104	293	129	200	23.6	
DMV-D	5100/11	226-073	226-075	7	DN 100	<b>13.8</b>	<b>4.7</b>	<b>13.0</b>	<b>5.6</b>	<b>8.7</b>	<b>67.5</b>	
						350	119	331	143	220	30.6	
DMV-D	5125/11	D226076	D226078	7	DN 125	<b>15.8</b>	<b>5.6</b>	<b>16.2</b>	<b>6.3</b>	<b>10.0</b>	<b>111.6</b>	
						400	142	412	161	255	50.6	
DMV-DLE	5040/11	226-115	226-117	7	DN 40	<b>9.5</b>	<b>2.5</b>	<b>8.7</b>	<b>3.9</b>	<b>5.9</b>	<b>17.4</b>	
						240	62,5	220	100	150	7.9	
DMV-DLE	5050/11	226-118	226-120	7	DN 50	<b>9.5</b>	<b>2.9</b>	<b>8.7</b>	<b>3.9</b>	<b>6.5</b>	<b>18.5</b>	
						240	73	220	100	165	8.4	
DMV-DLE	5065/11	226-102	226-103	7	DN 65	<b>11.4</b>	<b>3.4</b>	<b>10.6</b>	<b>4.0</b>	<b>7.3</b>	<b>32.6</b>	
						290	87	269	102	185	14.8	
DMV-DLE	5080/11	226-104	226-106	7	DN 80	<b>12.2</b>	<b>4.1</b>	<b>12.3</b>	<b>5.1</b>	<b>7.9</b>	<b>53.1</b>	
						310	104	312	129	200	24.1	
DMV-DLE	5100/11	226-112	226-114	7	DN 100	<b>13.8</b>	<b>4.7</b>	<b>15.1</b>	<b>5.6</b>	<b>8.7</b>	<b>68.6</b>	
						350	119	382	143	220	31.1	
DMV-DLE	5125/11	226-108	226-110	7	DN 125	<b>15.8</b>	<b>5.6</b>	<b>18.2</b>	<b>6.3</b>	<b>10.0</b>	<b>112.7</b>	
						400	142	462	161	255	51.1	

Equipment variants of DMV.../11 double solenoid valve, single-stage mode	DMV 5040/11 - DMV 5125/11
<b>DMV-D</b>	◇
<b>DMV-DLE</b>	◇
Sieve	◇
Gas pressure switch can be mounted:	
on flange	◇ Possible using a pipe nipple.
downstream of sieve	(◇)
downstream of valve 2	(◇)
Valve V1, double-seat	◇
Valve V2, double-seat	◇
Valves opening separately	◇
G 3/4 ignition gas flange can be mounted	(◇)

◇ = standard  
(◇) = on request  
-- = not possible

<b>DMV 5.../11 Flange Accessories</b>					
Size	*Weld neck part #	# of Holes	Bolt size	**Bolt part #	***Seal part #
DN 40	227-137	4	M16x55	135-940	100-164
DN 50	227-138	4	M16x55	135-940	030-221
DN 65	227-139	4	M16x65	135-930	099-408
DN 80	227-140	8	M16x65	135-930	030-254
DN 100	227-141	8	M16x65	135-930	030-304
DN 125	227-142	8	M16x75	148-830	030-312
DN 65 to 2 1/2"NPT	243-690	4	M16x65	135-930	099-408
DN 80 to 3"NPT	243-219	8	M16x65	135-930	030-254

\*When a control is used alone, one mating flange is needed for each end, for a total of two flanges.

When one control is bolted to another, such as an FRS to a DMV, one mating flange is needed for each end, for a total of two flanges

\*\* includes one bolt, one lock washer, and one nut

\*\*\* one seal needed for each flange

## Dual Modular Valve (DMV) system

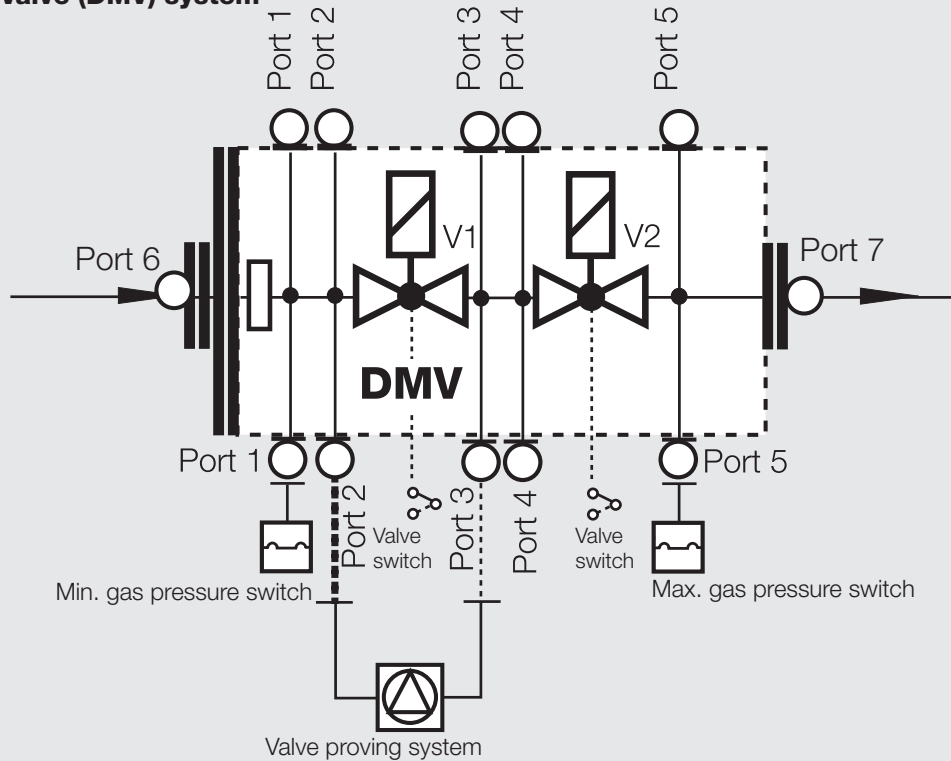

### Additional Accessories

#### VPS 504

Valve proving system (approved by some authorities having jurisdiction in lieu of vent valve and “proof of closure” e.g. FM and Swiss Re).

### GAO/GMH/GML A2 pressure switch

#### Position indication

**CPI 400** with indication lamps and SPDT interlock switch, or Visual indicator (VI)

#### DMK butterfly control valve

Mounts directly downstream of DMV to modulate gas flow. Requires actuator. Use DMA actuator with DMK butterfly valve.

### Adapters

- 1/4" NPT adapter (225-047)
- 1/2" NPT Pilot gas adapter; Check flow requirements. (225-043)
- G 1/8" Test nipple (219-008)

To determine the pressure drop when using a gas other than natural gas, use the flow formula below and f value located in the chart on the next page to determine the “corrected” flow rate in CFH through the valve for the other gas used. For example, when using propane, divide the volume (CFH) of propane required for the application by the calculated value f (f = 0.66 for propane). Use this “corrected” flow rate and the flow curve on the next page to determine pressure drop for propane.

$$\dot{V}_{\text{gas used}} = \dot{V}_{\text{Natural Gas}} \times f$$

Use this formula to calculator the f factor for other gases not listed on the table.

$$f = \sqrt{\frac{\text{Spec. gravity of Natural Gas}}{\text{Spec. gravity of gas used}}}$$

Type of gas used	Density [kg/m <sup>3</sup> ]	sg	f
Natural gas	0.81	0.65	1.00
Butane	2.39	1.95	0.58
Propane	1.86	1.50	0.66
Air	1.24	1.00	0.80

**Dual Modular Safety  
Shutoff Valves**

**DMV-D/11 Series  
DMV-DLE/11 Series**



**Flow curve**

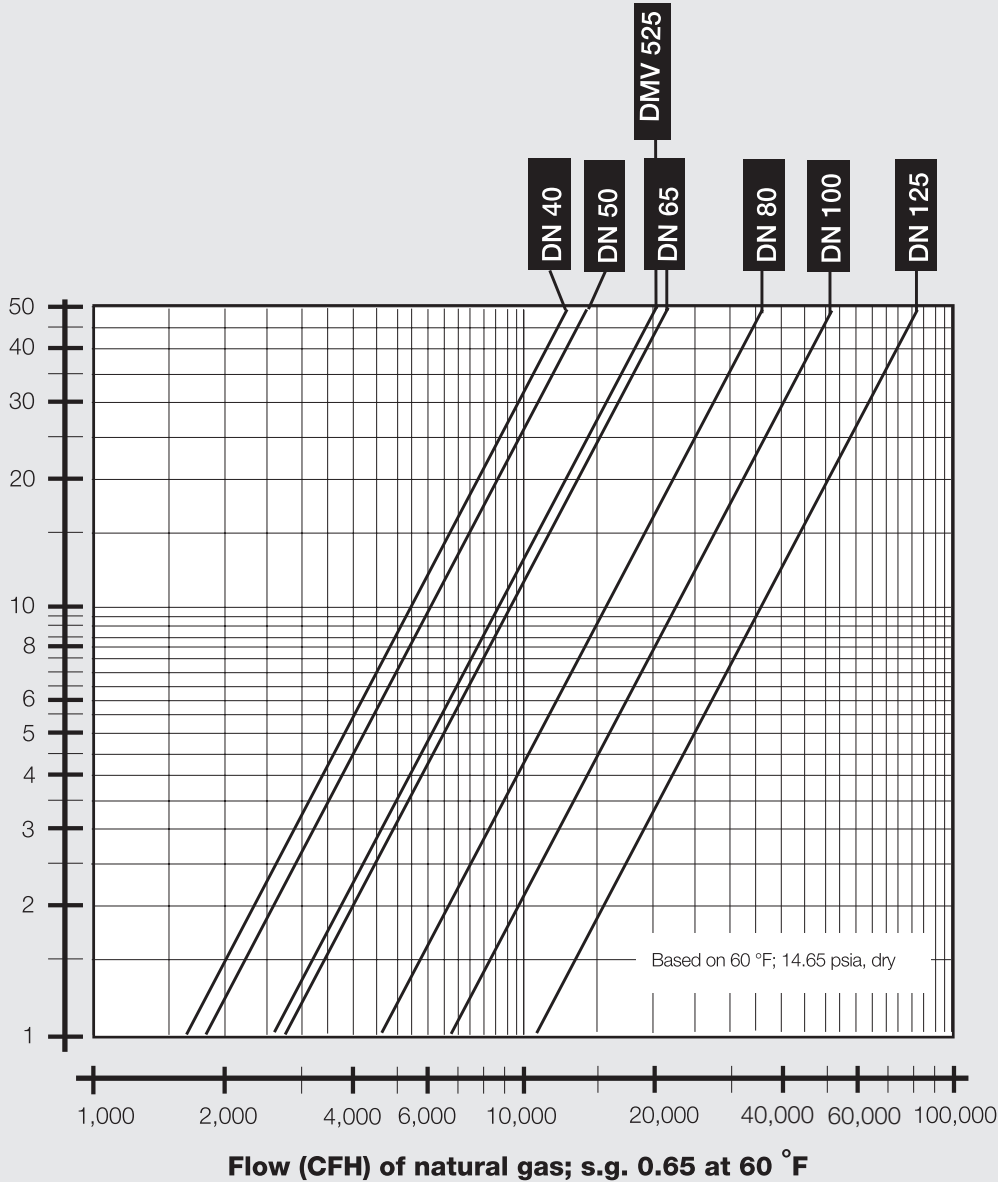

We reserve the right to make any changes in the interest of technical progress.

**Karl Dungs Inc.**  
**524 Apollo Drive, Suite 10**  
**Lino Lakes, MN 55014, U.S.A.**  
**Phone 651 792-8912**  
**Fax 651 792-8919**  
**e-mail info@karldungsusa.com**  
**Internet http://www.dungs.com/usa/**

**Karl Dungs GmbH & Co. KG**  
**P.O. Box 12 29**  
**D-73602 Schorndorf, Germany**  
**Phone +49 (0)7181-804-0**  
**Fax +49 (0)7181-804-166**  
**e-mail info@dungs.com**  
**Internet http://www.dungs.com**